

AER Slim

SERIES

“EVO” Version

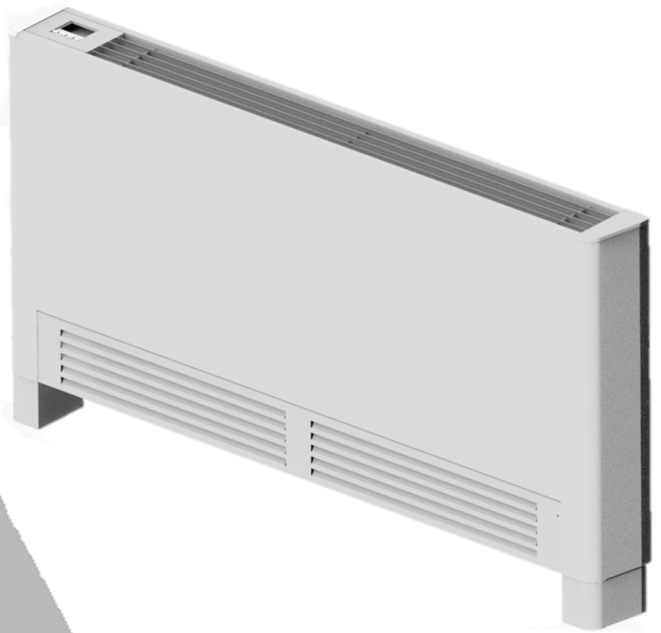

T E C H N I C A L M A N U A L

RESIDENTIAL
FCU
(thickness 119mm)



INDEX

1- INTRODUCTION	4
2- OPERATING RANGE.....	4
3- CODE COMPARISON SYSTEM.....	4
4-CONTROL AND COMFORT MANAGEMENT	5
5- TECHNICAL SPECIFICATION	6
6- TECHNICAL DATA.....	7
7- DIMENSION AND WEIGHT	8
7.1- Vertical version VB (left connections – SX)	8
7.2- Vertical version VB (right connections – DX).....	9
7.3- Vertical version VD (left connections – SX).....	10
7.4- Vertical version VD (right connections – DX)	10
7.5- Horizontal version HB (left connections – SX).....	11
7.6- Horizontal version HB (right connections – DX)	12
7.7- Horizontal version HD (left connections – SX)	13
7.8- Horizontal version HD (right connections – DX)	13
8- ACCESSORIES.....	14
8.1- Valve (V) and auxiliary drain pan (ADPB).....	15
8.2- Outercasing CCM	17
8.3- MPK outercasing panel.....	17
8.4- Outlet grille (GM2) and inlet grille (GR)	18
8.5- Telescopic plenum (RT).....	19
9- ELECTRICAL DIAGRAM.....	20

1- INTRODUCTION

The series AERSLIM units are designed for residential and commercial air conditioning, for indoor installation, not exposed to ice or extreme temperatures, non-dusty and non-explosive environments. The manufacturer is not responsible for incorrect use.

The AERSLIM series is offered with DC inverter motors, which allow low power consumption and high silence.

2- OPERATING RANGE

Power supply	220 ÷ 240V / 50Hz
Water inlet temperature	5÷ 70°C
Air inlet temperature	10÷ 35°C
Relative Humidity inlet air	15 ÷ 70%

It is recommended to operate at the extremes of the above operating limits only for short periods of time, as long periods of operation may reduce the normal life of the components.

3- CODE COMPARISION SYSTEM

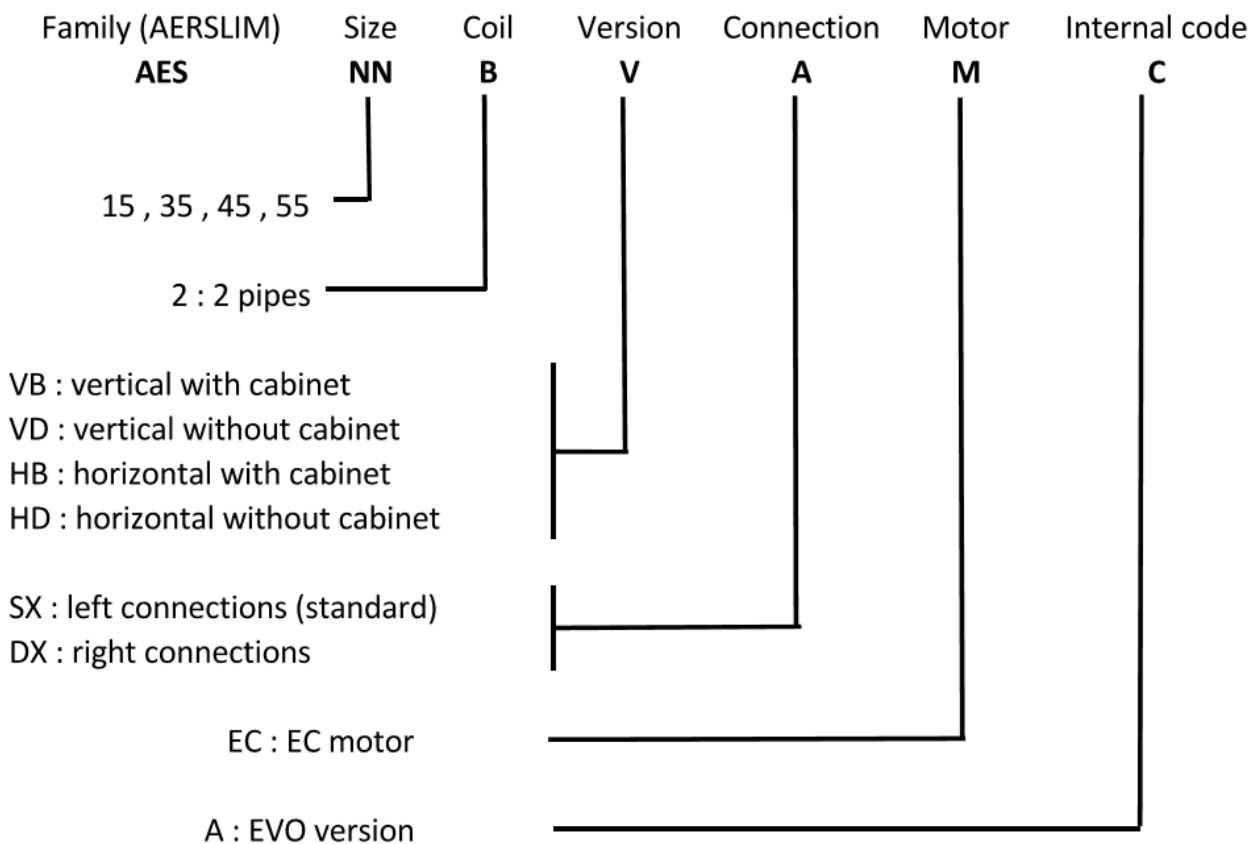

4-CONTROL AND COMFORT MANAGEMENT

The unit is controlled by power board SP3-BLDC installed on the unit (supplied as standard). This board can be used with keypad TOP3 (installed on the unit or on the wall) or with infrared control or with additional board for BMS systems (Modbus protocol). It's also possible to realize master-slave connection between master units (equipped with TOP3 keypad or infrared control) and slave units. According to the configuration, other probes (water or air temperature) can be necessary. For further information regarding the control, see the specific manual.



Comfort have been improved with many functions, the most relevant are the following:

- Automatic summer/winter selection
- Automatic fan speed selection
- “Night mode” : when this mode is activated, the control change automatically the fan speed according to room temperature, limiting that speed not to disturb the night rest.
- “Nearly radiant mode” (PATENT PENDING) : this mode is always active with 2 pipes systems with valve in heating mode. Thanks to the special management of valve and fan, when the set-point is reached, desired temperature is maintained with nearly zero motor electric power (< 3W), air draft and noise level imperceptible (< 20 dB(A)), so the result is very similar to the one obtained with static heating with radiant plate.

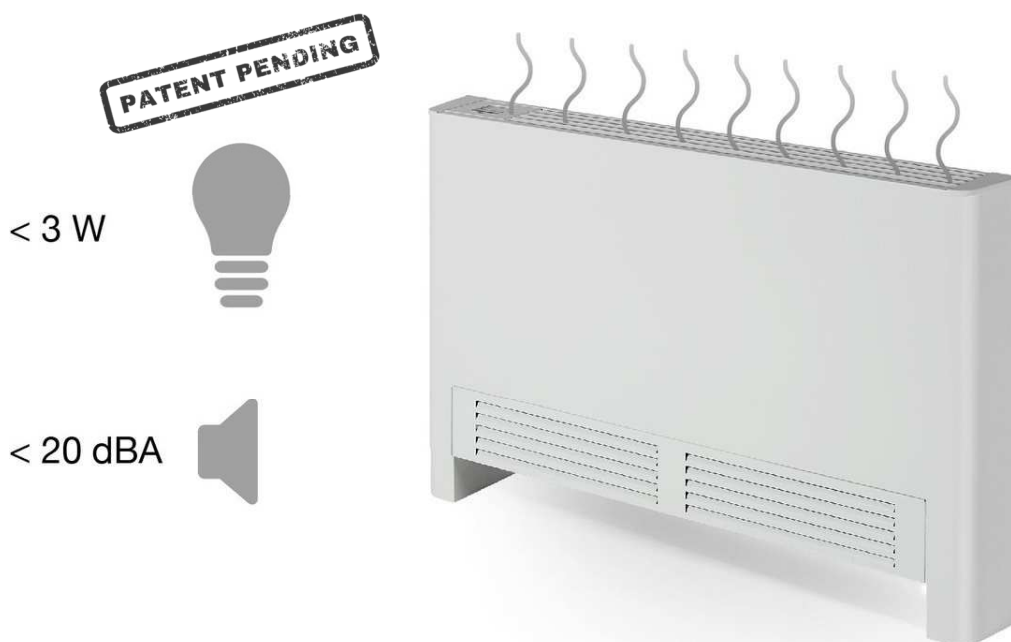

5- TECHNICAL SPECIFICATION

STRUCTURE: made of galvanized steel sheet thickness 0,80-1,00mm. The robust structure prevents vibrations and includes fixing brackets.

CABINET: Made of painted and pre-painted (RAL 9003) sheet of 0.8mm thick. The pleasing design and reduced thickness (only 119mm) perfectly fits into any environment. The delivery grid can be easily rotated by 180 ° to turn the air flow to the environment or to the wall.

ACCESSIBILITY: The filter can be removed by opening the front suction panel. Accessibility to internal components (fan, electric panel and valve) is guaranteed by removing the entire cabinet. Hydraulic connections are standard on the left side (looking in front of the fan coil); right connection on request. The electric panel on the opposite side.

FILTER: G1 class (EN779), polypropylene net.

IMPELLER: The impeller is tangential type, made of reinforced plastic material, balanced and equipped with rubber vibration dampers to ensure no vibration.

MOTOR: DC inverter motor with high-efficiency permanent magnets, power and speed regulated with an electronic device that eliminates vibration and noise, reduced fuel consumption and a wide range of fan speed modulation.

COIL: Made with high efficiency copper corrugated tubing and aluminum fins, with manual air vent valve at the top. Nominal pressure PN10. Hydrophilic treatment to increase heat exchange even in the presence of high humidity.

DRAIN PAN: Made of ABS plastic, material free of corrosion in contact with condensate water. The shape of the pan facilitates the outflow and guarantees absence of water stagnation.

INSULATION: fan coil body insulated with expanded polyethylene 3mm thick foam. Insulated front panel with expanded polyurethane thickness 10mm.

ELECTRICAL PANEL: Made of galvanized steel sheet and positioned on the opposite side of the hydraulic connections.

"NEARLY RADIANT" MODE: to maintain high level of comfort after reaching the set-point.

119 mm.

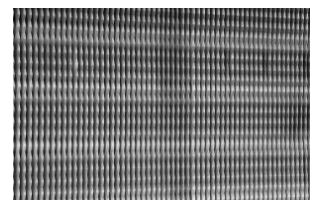
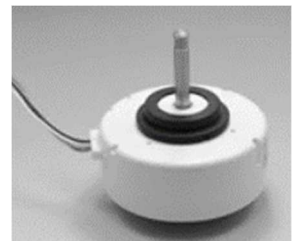

6- TECHNICAL DATA

SIZE	15			35			45			55			
	min	med	max	min	med	max	min	med	max	min	med	max	
Speed													
Air flow capacity	mc/h	60	130	180	120	235	340	175	340	500	215	415	600
COOLING – air 27°C d.b. , 19°C w.b. – inlet water 7°C , outlet water 12°C													
Total capacity	kW	0.37	0.66	0.83	0.74	1.24	1.61	1.14	1.93	2.56	1.46	2.48	3.28
Sensible capacity	kW	0.28	0.53	0.68	0.56	0.98	1.32	0.85	1.49	2.02	1.07	1.88	2.53
Water capacity	l/h	63	114	142	127	214	277	196	332	440	250	427	564
Pressure drop Δp	kPa	2	6	9	2	4	6	4	11	18	8	20	33
HEATING – air 20°C – inlet water 45°C outlet water 40°C													
Total capacity	kW	0.40	0.75	0.97	0.80	1.40	1.88	1.18	2.07	2.83	1.47	2.59	3.51
Water capacity	l/h	69	131	168	137	242	325	204	359	490	254	449	607
Pressure drop Δp	kPa	2	7	10	2	5	7	4	11	19	7	19	33
POWER CONSUMPTION													
Power	W	5	6	11	6	11	19	7	12	20	9	15	24
Max current	A	0,1			0,2			0,2			0,2		
NOISE DATA													
Sound Power	dB(A)	37	45	53	38	46	53	38	46	54	38	46	54
Sound Pressure	dB(A)	28	36	44	29	37	44	29	37	45	29	37	45
ENERGY LABEL													
FCEER													
FCCOP													

7- DIMENSION AND WEIGHT

7.1- Vertical version VB (left connections – SX)

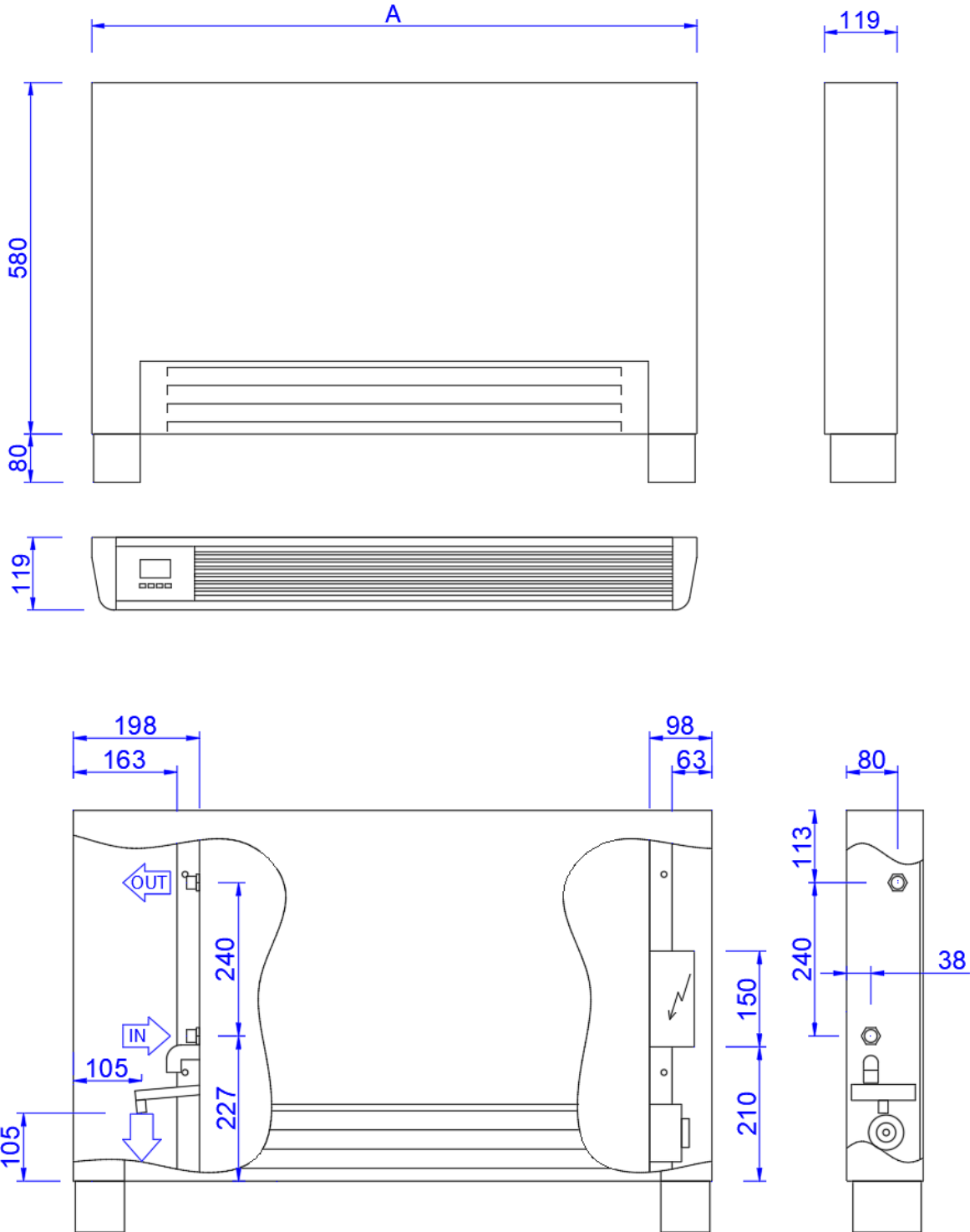

7.2- Vertical version VB (right connections – DX)

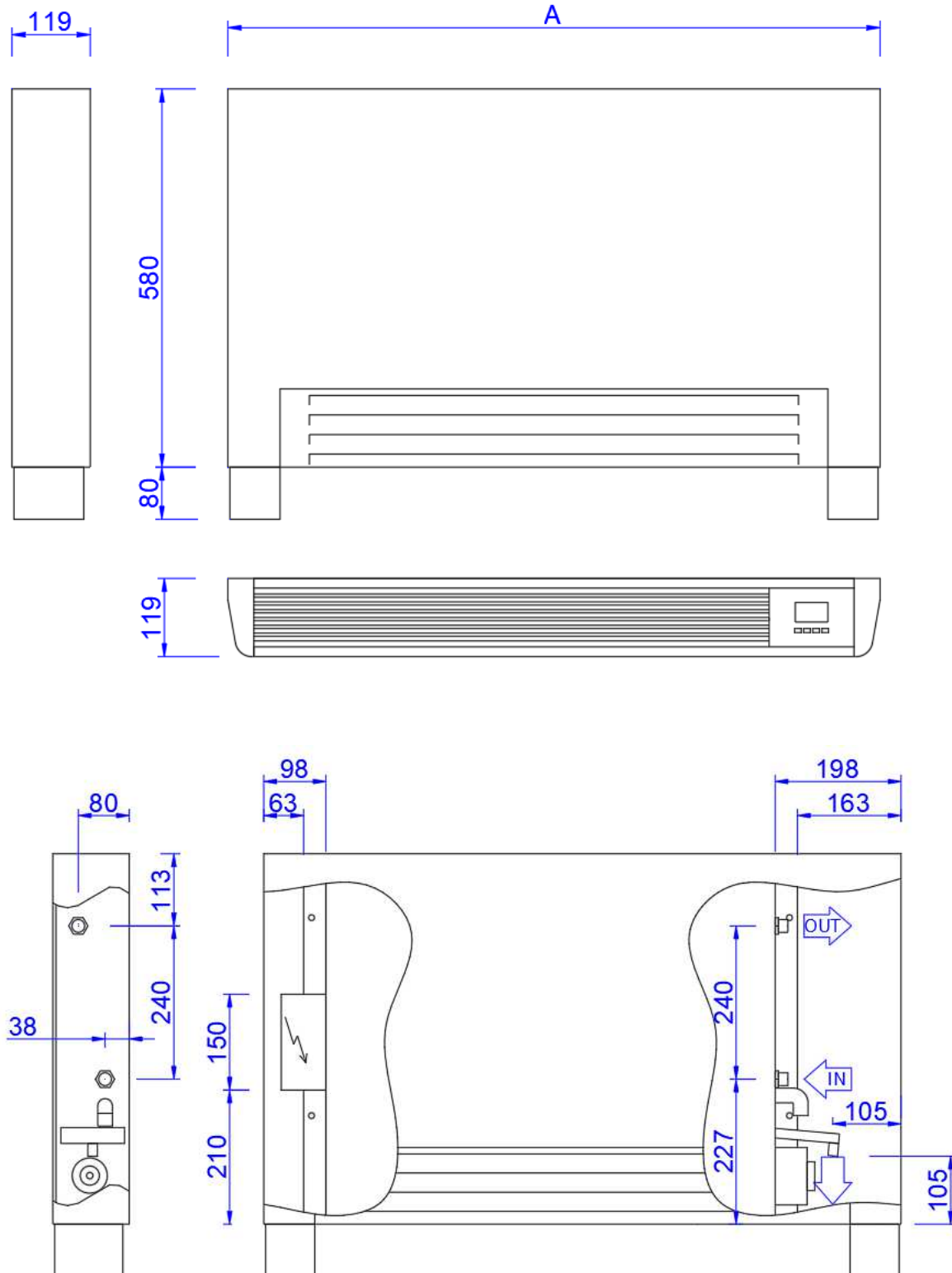

7.3- Vertical version VD (left connections – SX)

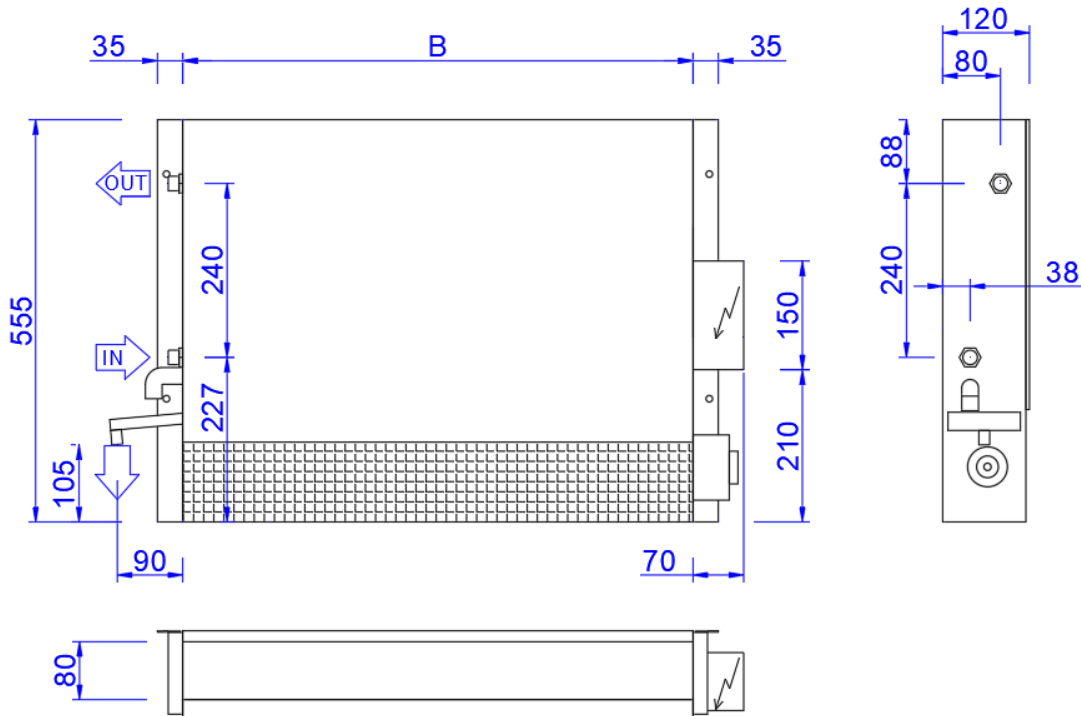

7.4- Vertical version VD (right connections – DX)

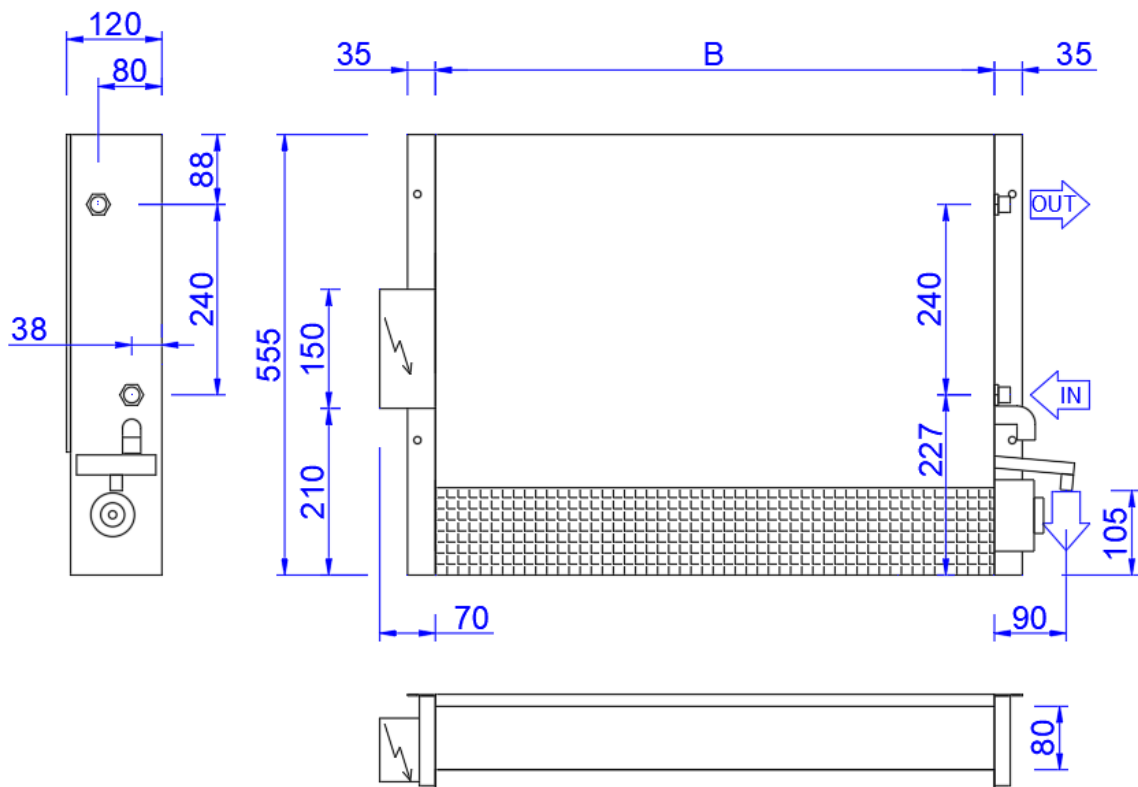

7.5- Horizontal version HB (left connections – SX)

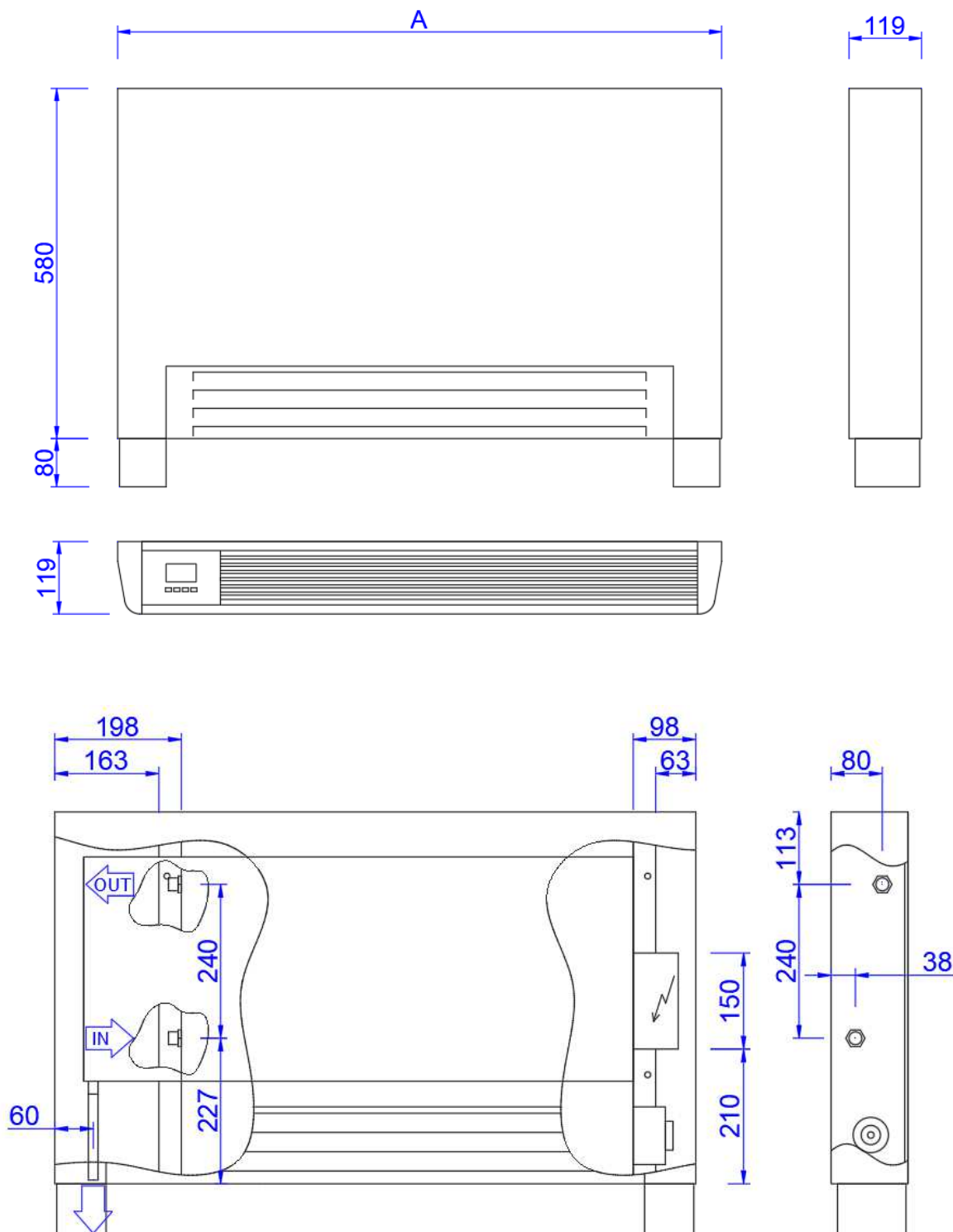

7.6- Horizontal version HB (right connections – DX)

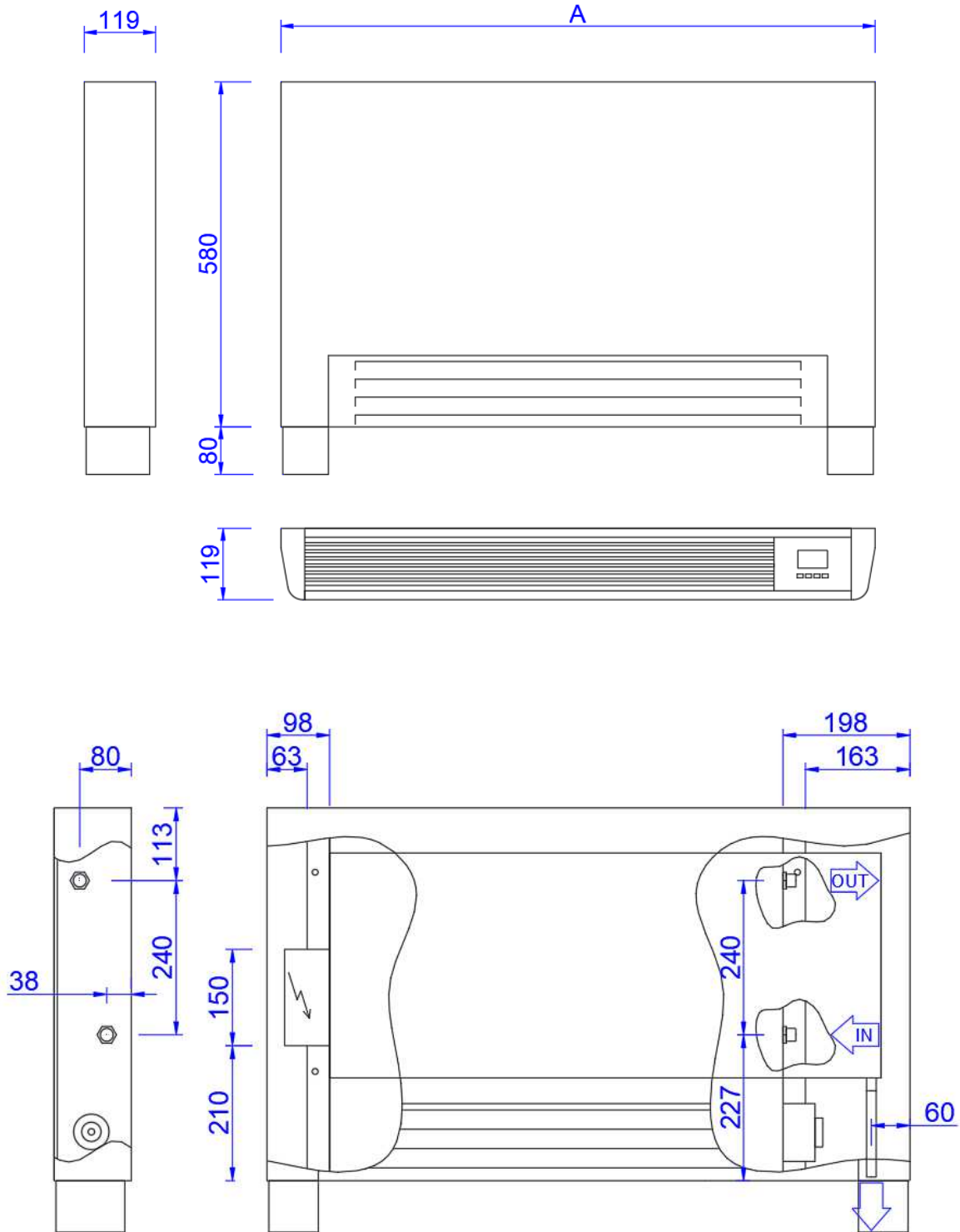

7.7- Horizontal version HD (left connections – SX)

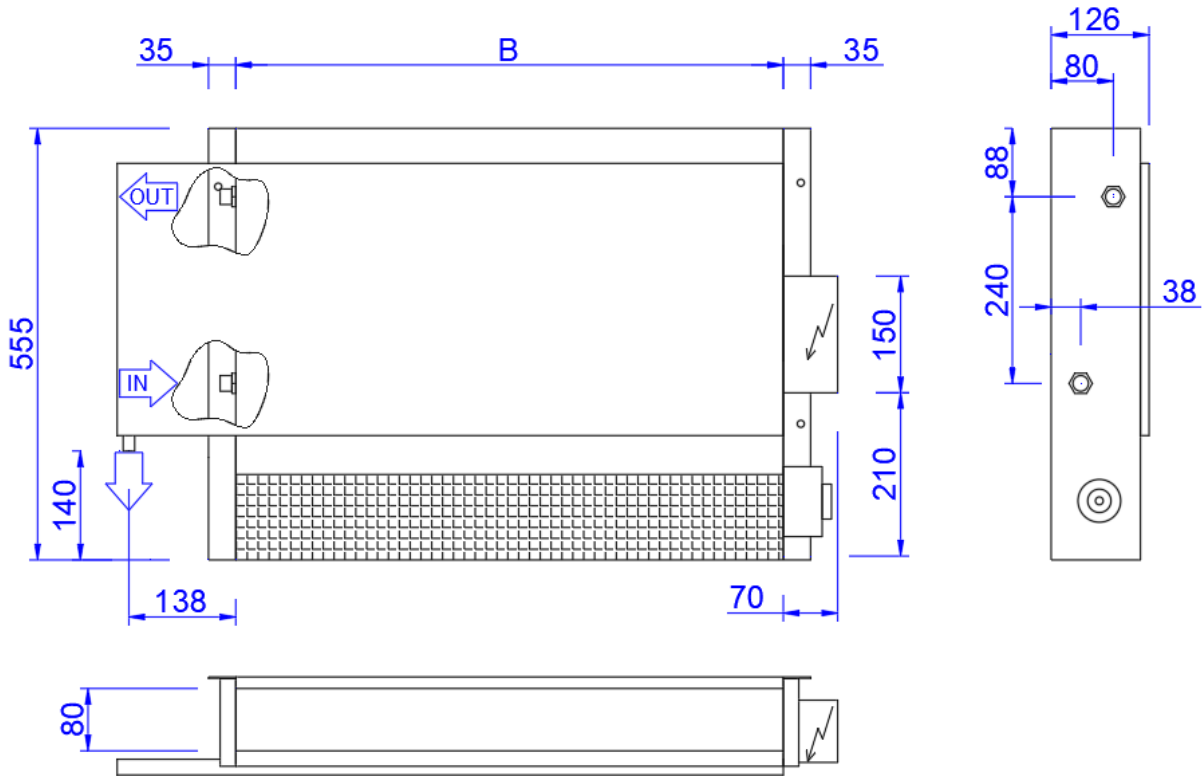

7.8- Horizontal version HD (right connections – DX)

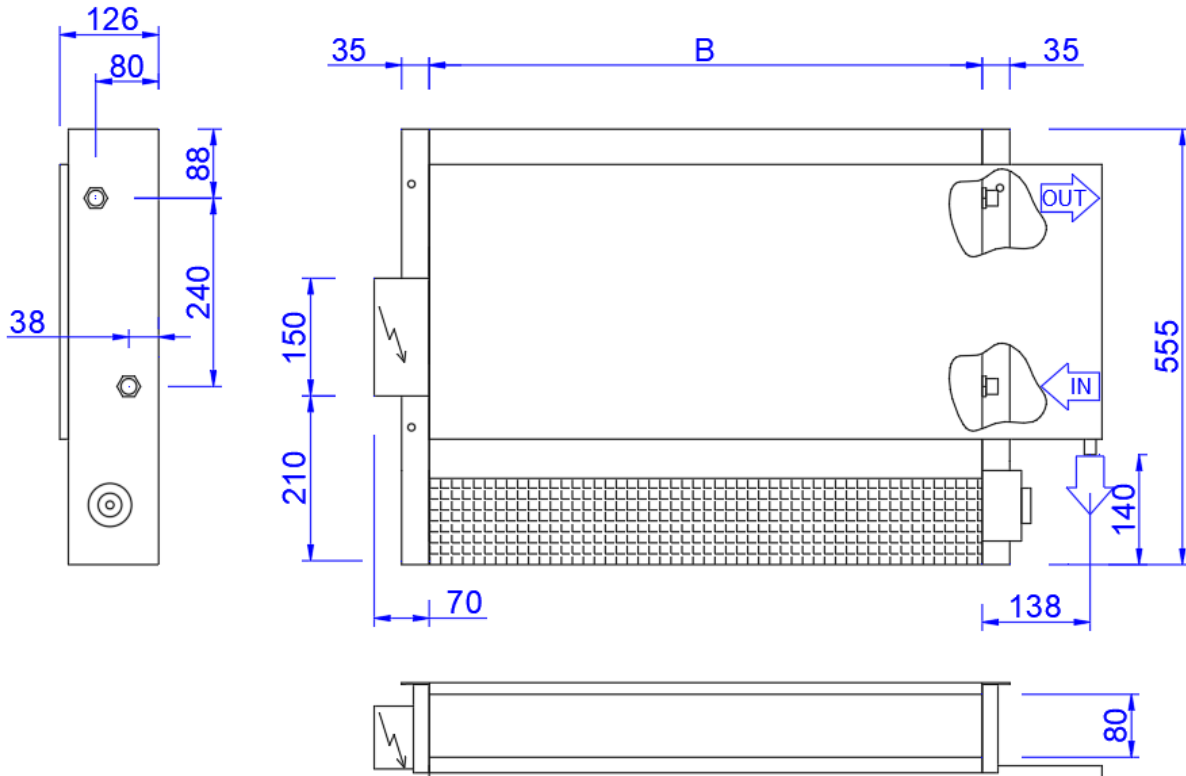

DIMENSION		15	35	45	55
A	mm	600	800	1000	1200
B	mm	305	505	705	905
Water connections	"	1/2"	1/2"	1/2"	1/2"
Drain pipe connection (vertical)	mm	d.14	d.14	d.14	d.14
Drain pipe connection (horizontal)	mm	d.16	d.16	d.16	d.16

WEIGHT		15	35	45	55
Weight model (VB-HB)	kg	17	20	23	26
Weight model (VD-HD)	kg	9	12	15	18
Total water in the coil	liters	0.47	0.8	1.13	1.46

8- ACCESSORIES

Accessories availables:

	HYDRAULIC ACCESSORY	A/K/C
V22	2 way valve ON-OFF 230V	A/K
V23	3 way valve ON-OFF 230V	A/K
ADPB	Auxiliary drain pan (included in the standard supply)	A
	INSTALLATION ACCESSORY	
CZ	Feet set	K
CCM	Outercasing for wall installation (for vertical version VD)	B
MKP	Panel for outercasing CCM	B
	CONTROL	
TOP-3	Wall mounting display	B
TOP-3-BI	On board display	A

A/K/C: A=accessory supplied installed un the unit; K=accessory supplied not installed (kit); B= Assembled supplied assembled, but not installed on the main unit.

8.1- Valve (V) and auxiliary drain pan (ADPB)

The use of motorized valves is recommended to avoid condensation on the surface of the unit when the fan is in stand-by.

Valves can be supplied assembled to the unit or kits (disassembled components).

The auxiliary condensate drain pan is supplied as standard with the unit without extra costs. (ADPB).

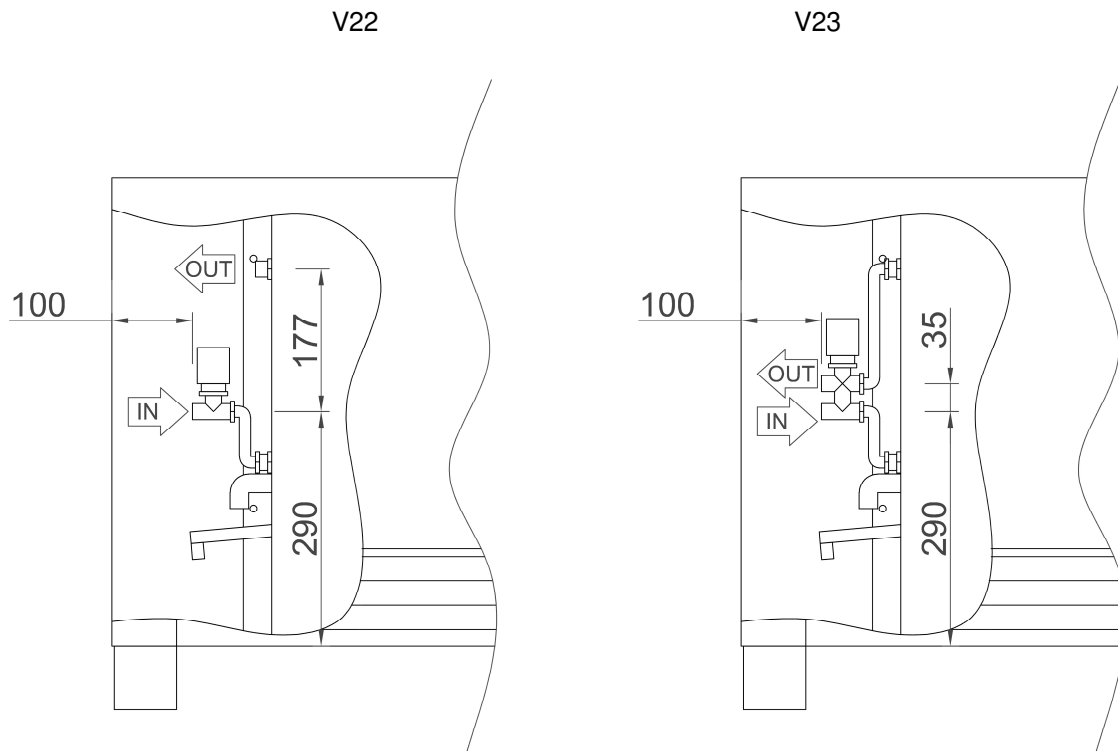

VALVE FOR MAIN COIL	15-35-45-55
MAIN DATA	
Connection dimension	1/2"
Kv (2 way valve)	1,7
Kv (3 way valve, straight)	1,7
Kv (3 way valve, by-pass)	1,2
Max pressure drop	2,0bar
Nominal pressure	16bar
Water temperature range	4-110°C
Power supply	230V-50Hz
Power adsorbed	2,5W
Valve Open/Close time	180s
Type (valve+actuator)	N.C. (Normally closed)
Protection/insulation	IP44

AER Slim

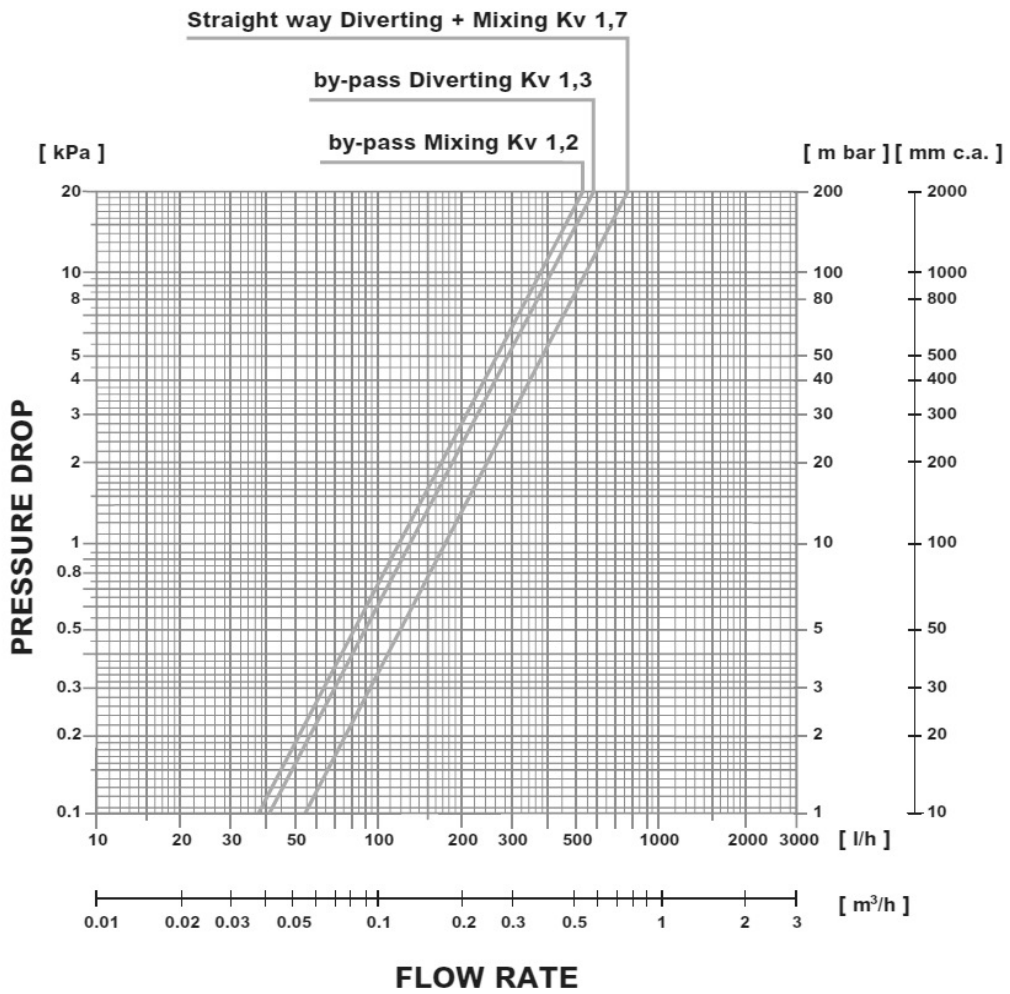

8.2- Outercasing CCM

Outercasing CCM is only for vertical installation, suitable with Aerslim model VD. It's realized in galvanized metal sheet. There are pre-hole for pipes in the side, in the back and down.

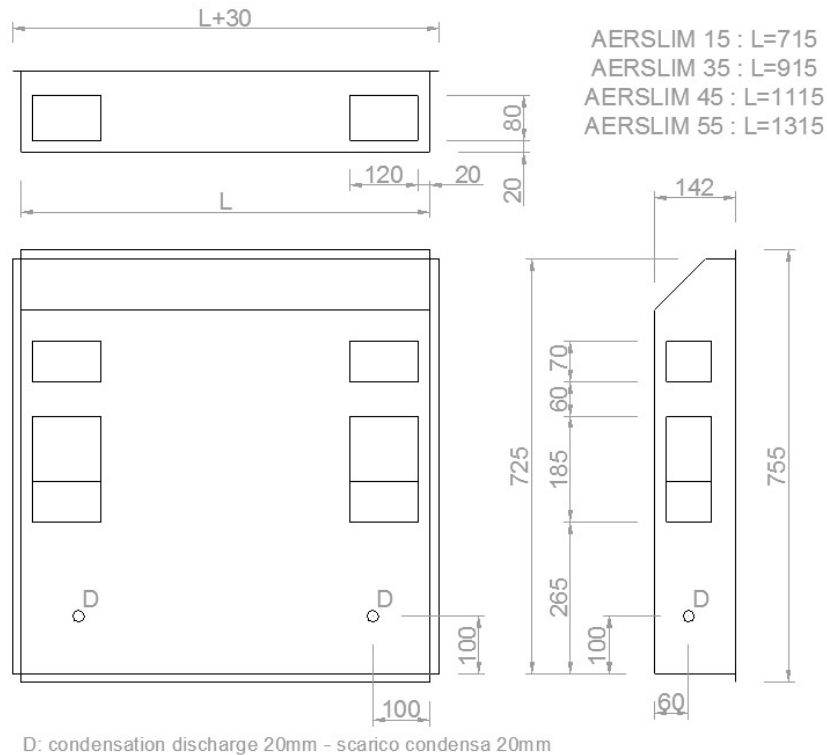

8.3- MPK outercasing panel

Realized in galvanized and painted (RAL 9003) metal sheet, it's suitable with outcasing CCM.

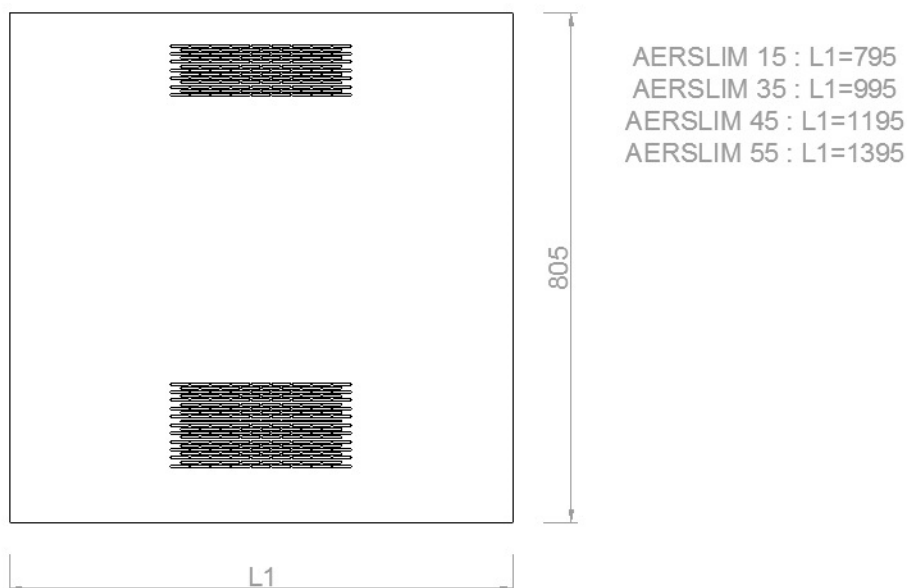

8.4- Outlet grille (GM2) and inlet grille (GR)

Outlet double regulation grille and fixed blades inlet grille are made in aluminum. Outlet grille have the possibility to regulate air flow in horizontal and vertical direction. In the grille frame there are fixing holes for screws, so grilles can be placed on the wall and on the ceiling.

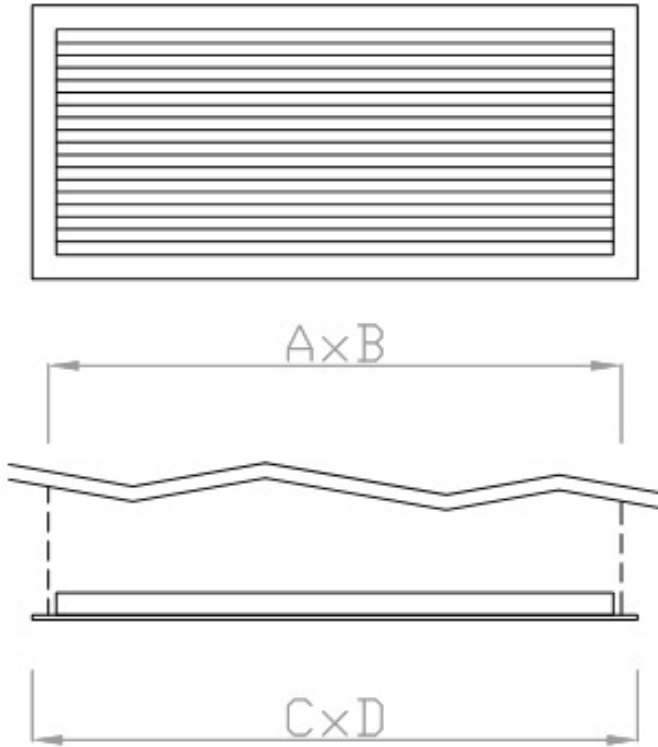

DIMENSIONS GM2 (mm)

	15	35	45	55
A	310	510	710	910
B	100	100	100	100
C	342	542	742	942
D	132	132	132	132
A,B : nominal hole dimensions				
C,D can vary from +/-10mm				

DIMENSIONS GR (mm)

	15	35	45	55
A	310	510	710	910
B	120	120	120	120
C	342	542	742	942
D	152	152	152	152
A,B : nominal hole dimensions				
C,D can vary from +/-10mm				

8.5- Telescopic plenum (RT)

Telescopic plenum can be installed in the outlet, between the unit and outlet grille GM2. As standard, the plenum is supplied not insulated, if thermic insulation is needed, it's necessary to order the accessory COIB (insulation for plenum).

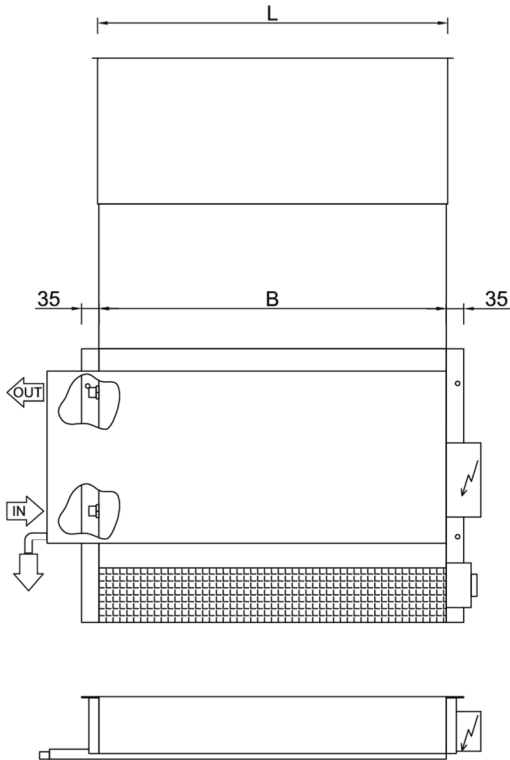

	B	L
AERSLIM 15	305	310
AERSLIM 35	505	510
AERSLIM 45	705	710
AERSLIM 55	905	910

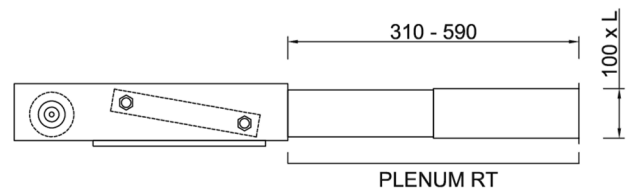

9- ELECTRICAL DIAGRAM

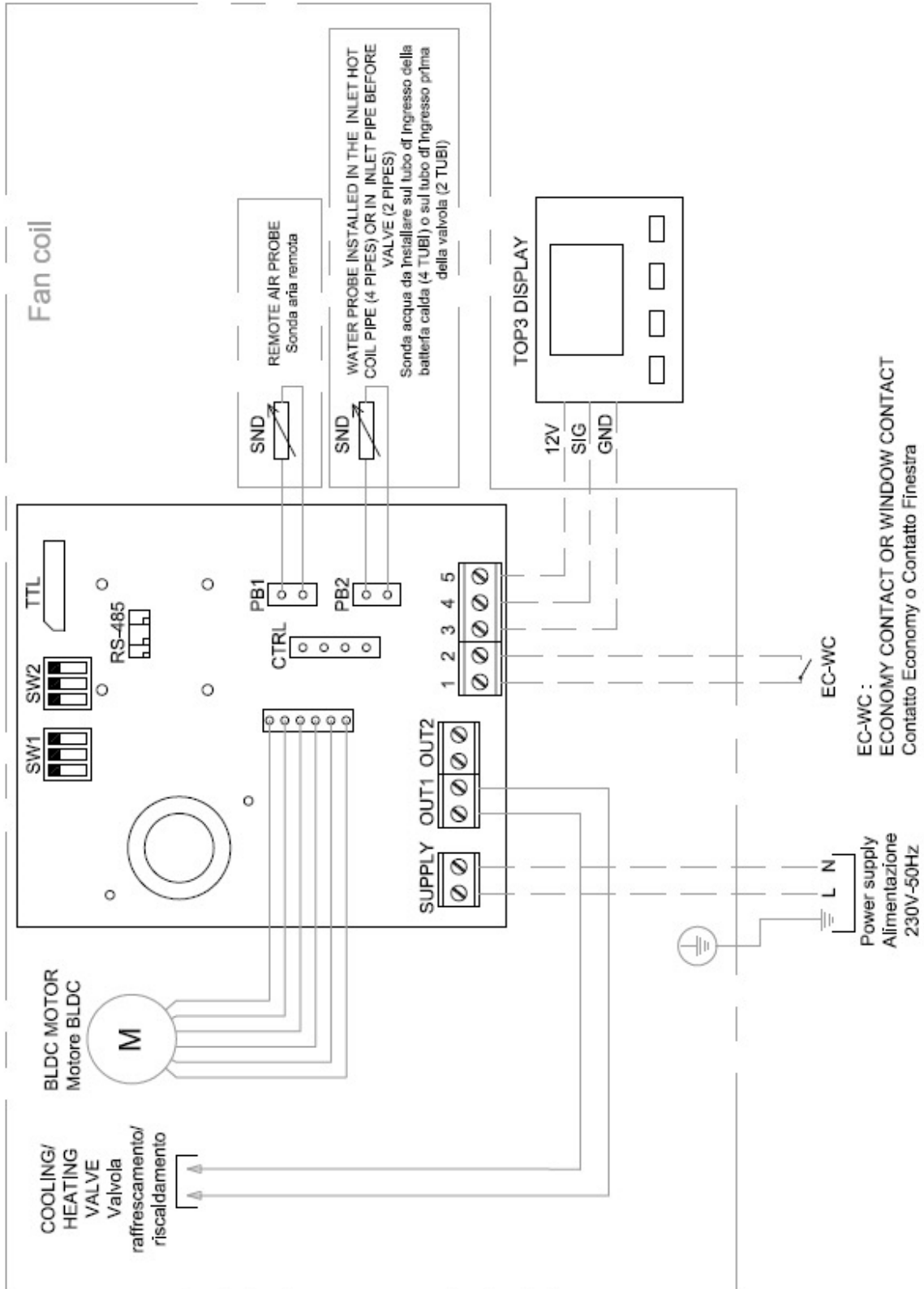

RESIDENTIAL FAN-COIL- TECHNICAL MANUAL

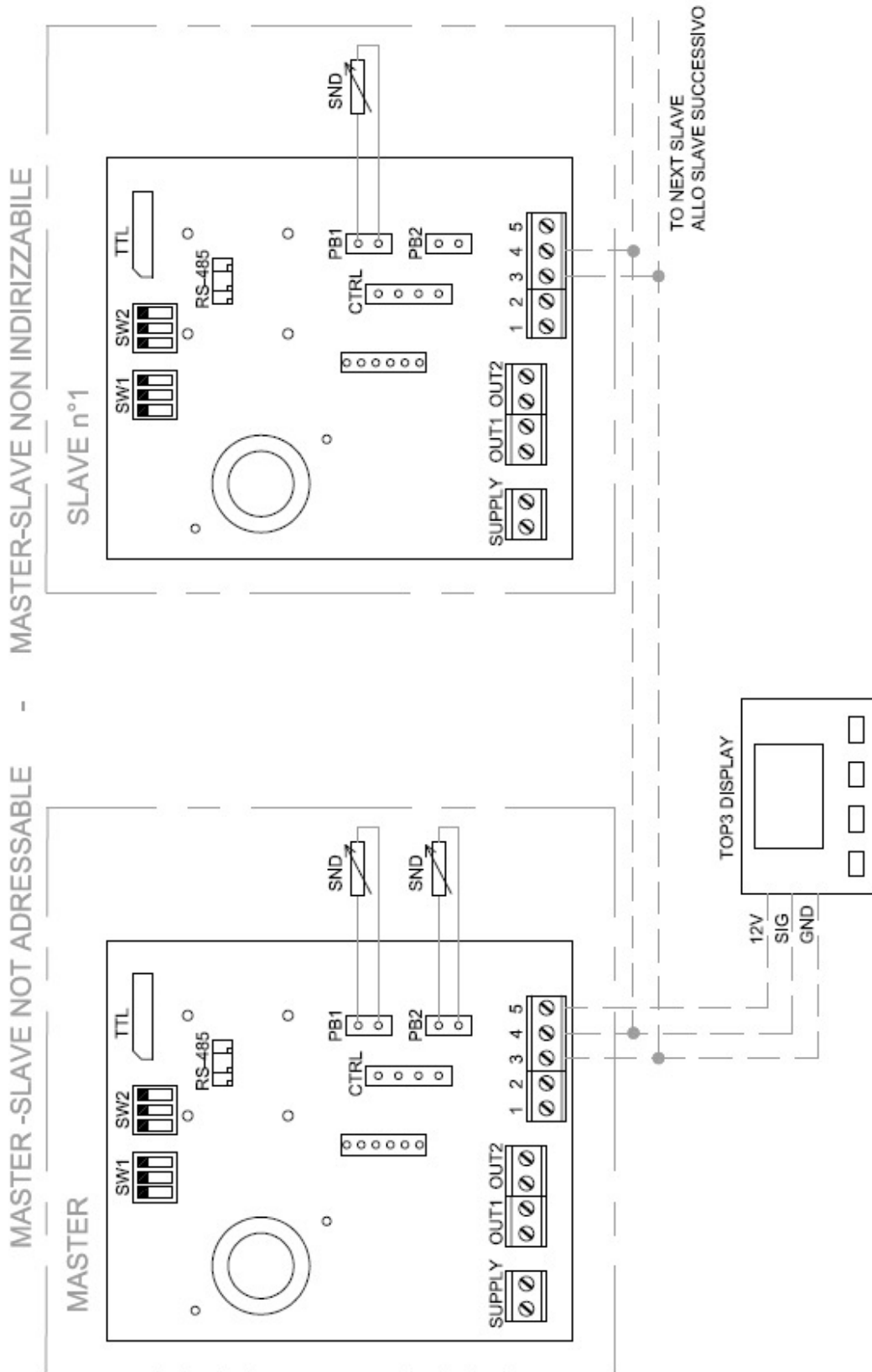



something different

AER.MT.AES.GB.005.08.19